





**KAYAN**

**KAYAN FIRE & SMOKE CURTAIN**

**Catalogue**

 0580534444

 [Info@kayancomp.com](mailto:Info@kayancomp.com)

 [www.kayancomp.com](http://www.kayancomp.com)

## ABOUT US

We specialize in certified fire and smoke curtain systems services for domestic, commercial and industrial use.

We are proud to be one of the best national companies in the field of fire and smoke curtains with our clients ranging from high-level international organizations across multiple sectors to industry and local clients in the Kingdom of Saudi Arabia

All our products are made to the highest quality, and we constantly work to achieve the highest possible standards with our systems complying with British and European regulations and standards.

## من نحن

نحن متخصصون في خدمات أنظمة ستائر الحريق والدخان المعتمدة للاستخدام المنزلي والتجاري والصناعي . نفخر بكوننا واحدة من أفضل الشركات الوطنية في مجال ستائر الحريق والدخان مع عملائنا بدءاً من المنظمات الدولية رفيعة المستوى عبر قطاعات متعددة إلى الصناعة والعملاء المحليين في المملكة العربية السعودية جميع منتجاتنا مصنوعة بأعلى مستويات الجودة ، ونحن نعمل باستمرار لتحقيق أعلى المعايير الممكنة مع امتثال أنظمتنا الانظمة والمعايير البريطانية والأوروبية

## Our Mission

is to ensure our clients receive the product manufactured to the highest quality, with reliable certifications and standards We are concerned about the safety of end users, which makes us responsible for committing in manufacturing life safety systems of world-class standards

## مهمتنا

هي ضمان حصول عملائنا على المنتج المصنَّع بأعلى مستويات الجودة، مع شهادات ومعايير موثوقة . نحن مهتمون بسلامة المستخدمين النهائيين، مما يجعلنا مسؤولين عن الالتزام في تصنيع أنظمة السلامة بمعايير عالمية .

# APPLICATIONS

**1- VOID EDGE SEPARATION** Escalators and stairs create gaps between floors. These gaps are critical points that need to be sealed off in the event of a fire to stop the spread of fire and smoke from lower to upper levels. By deploying on the upper level, fire curtains create a physical barrier against fire.



**2- SMOKE RESERVOIRS** Escalators and stairs create gaps between floor compartments that need to be sealed off in the event of a fire to stop the spread of fire from lower to upper levels.

**3- LIFT LOBBY & ELEVATOR SEPARATION** Elevator shafts are easy conduits for the spread of fire and smoke which can engulf an entire building in minutes. Elevator doors might be fire rated but cannot create a seal against the passage of smoke. Fire curtains with a smoke seal replace smoke stop lobbies in front of the elevator doors. While virtually invisible when retracted above the elevator frame, they create a seal that greatly reduces smoke leakage through elevator shafts and elevator doors

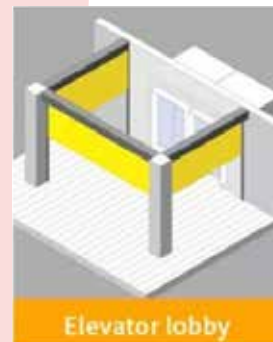

**4- FIRE COMPARTMENTALIZATION** To prevent spread of fire from one zone to another, fire curtains are a vital element of a fire compartmentalization strategy. On deployment, they create a physical barrier against the spread of fire and control the spread of fire through a building.

**5- FIRE & SMOKE STRATEGY KAYAN** Automatic Fire and Smoke Curtains are indispensable to a successful building fire strategy. Atria create large open spaces that can be quickly engulfed in fire and smoke as it spreads from lower to upper levels. Spread of fire can be limited by fire curtains and smoke curtains can channel smoke to chimneys or extraction fans



**KAYAN fire & smoke curtain make up of fiberglass fabric inside stainless steel wire, with double-sided silicone coating material. Smoke curtain can be applied in escape route, elevator door, elevator lobby, escalators and stairs, Atrium Chimney ,etc.**



## KAYAN CONTROL SYSTEM

The KAYAN Tubular Motor is a permanent magnet DC electrical motor. When the curtains are retracted, the KAYAN Motor Controller (KMC) routes a low voltage supply to the motor which keeps it in the retracted position.

When the fire alarm signal is triggered, the low voltage supply to the KMC is removed which in turn deploys the curtains to their fire operational position under the power of gravity.

المحرك الأنبوبي كيان هو محرك كهربائي بمغناطيس دائم يعمل بالتيار المستمر .

عندما يتم سحب الستائر تقوم وحدة التحكم ( KMC ) كيان بتوجيه مصدر جهد منخفض إلى المحرك مما يبقيه في وضع التراجع.

عندما يتم تشغيل إشارة إنذار الحريق، تتم إزالة مصدر الجهد المنخفض إلى لوحة التحكم كيان

والذي بدوره ينشر الستائر إلى موقعها تحت قوة الجاذبية .

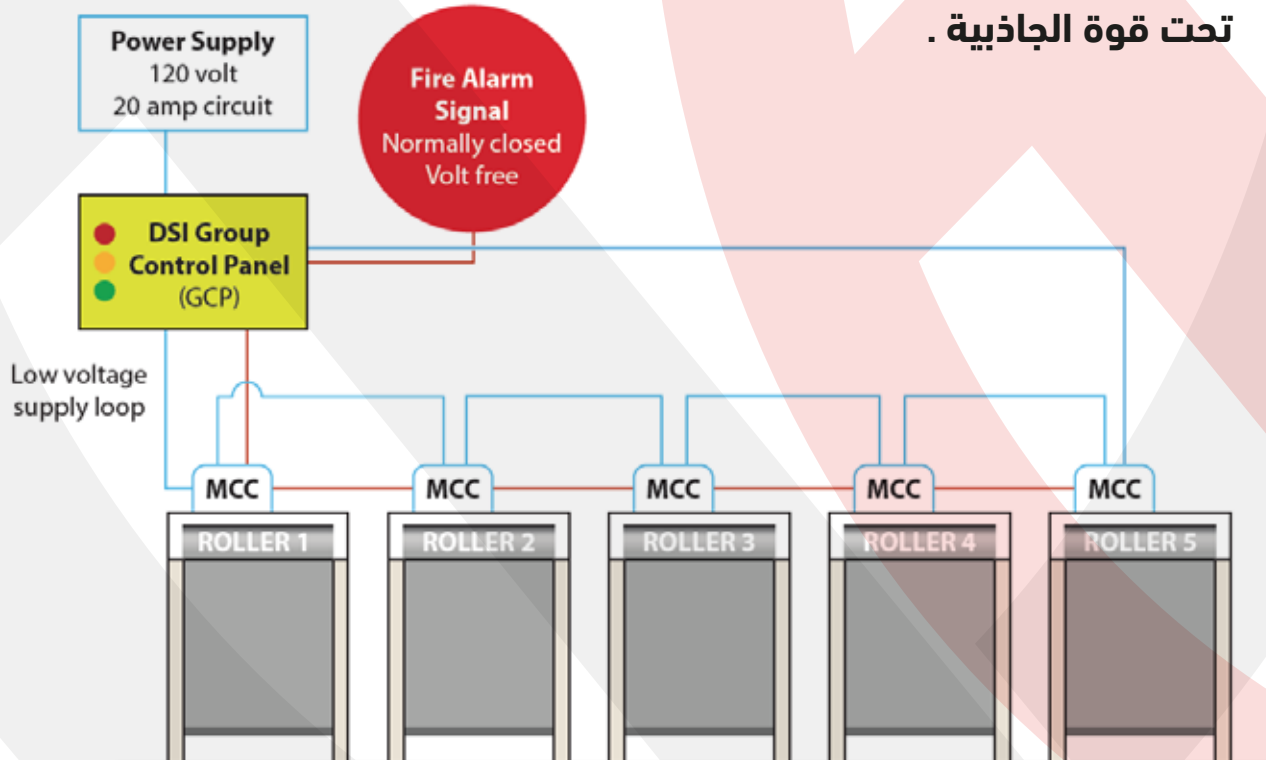

## IN CASE OF FIRE ALARM

The KAYAN Group Controller (KGC) is powered by a 230v AC power supply. A pair of normally-closed, volt-free fire alarm contacts supplies the fire alarm signal when commanded by the Building Management System. In its stored position within the headbox, the curtains remains retracted and held in place by a low voltage supply (24v DC) to the curtain motors. Upon receipt of a fire alarm signal, the supply to the motor controller is removed , which releases the curtains. Using Kent's Guaranteed Gravity Fail Safe System, the curtains deploy to the operational position at a controlled rate under the force of gravity. No power source is required for curtain deployment

## في حالة استلام إشارة إنذار الحريق

يتم تشغيل وحدة التحكم كيان بمصدر طاقة تيار متردد 220 فولت في حالة انقطاع التيار الكهربائي، يتم تزويد كل مجموعة تحكم بنظام احتياطي بطارية يوفر ما يصل الي 60 دقيقة من الطاقة لمحركات الستائر. عند استنفاد البطاري الاحتياطية ، ستنزل الستارة بأمان تحت الجاذبية



## CURTAIN FBRICS

An important component of a fire and smoke curtain system is the fabric. The fabric is designed to withstand heat, smoke, fire, including high temperatures.

The finished product is sewn with stainless steel thread at hem and seam locations formulated light weight fibreglass fabric, coated with aluminum pigmented polyurethane on both sides of the fabric which creates a reflective heat shield and enhances durability and flexibility of the fabric.

يعد القماش أحد العناصر المهمة في نظام ستائر الحريق والدخان .  
تم تصميم القماش ليتحمل الحرارة والدخن والنار ، بما في ذلك درجات الحرارة المرتفعة . تتم خياطة المنتج النهائي بخيط من الفولاذ المقاوم للصدأ في مواقع الحاشية والدرزات، وهو مصنوع من نسيج من الألياف الزجاجية خفيف الوزن، ومغطى بمادة البولي يوريثين المصبوغة بالألمنيوم على جانبي القماش مما يخلق درعاً حرارياً عاكساً ويعزز متانة ومرونة القماش

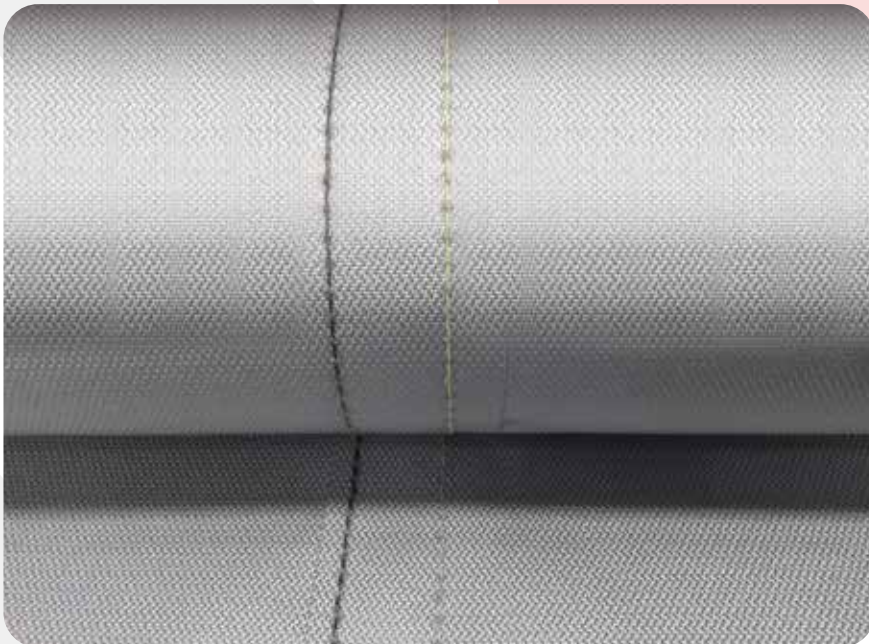

## Bottom bar

It installed at the bottom, end of the fabric to effectively keep the fabric flat

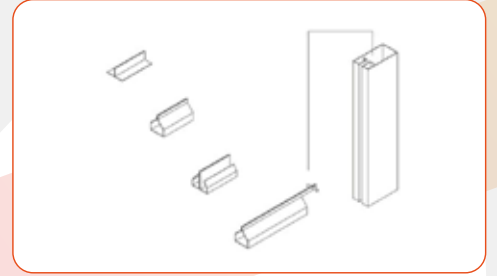

## Guide rail

Guide rail should be installed on both sides of the curtain to reduce smoke leakage.

Guide rail classification:

Middle fixing, fixed in the middle of the wall

Side fixing, fixed on the side of the wall

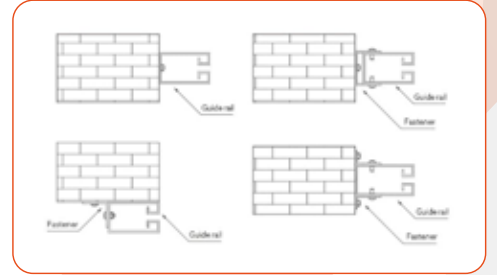

## Headbox

The function of the headbox is to facilitate construction and effectively protect the motor and the curtain from damage.

It is divided into single roller model and double roller model.

Double roller model can be divided into vertical type and horizontal type according to the structure limit of the building .

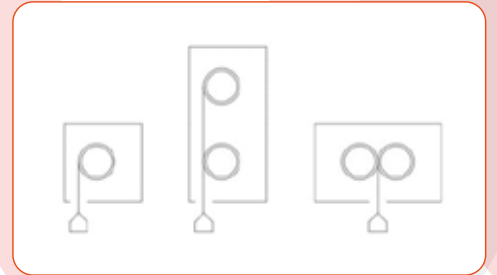



**KAYAN**

**KAYAN FIRE & SMOKE CURTAIN**

**CUTSHEET**

 0580534444

 [Info@kayancomp.com](mailto:Info@kayancomp.com)

 [www.kayancomp.com](http://www.kayancomp.com)



**KAYAN**

شركة كيان للسلامة

# KAYAN AUTOMATIC FIRE CURTAIN

## CUTSHEET

### FIRE CURTAIN BOXES

Diagram of Single Roller Box - Type 1 showing dimensions: BW (BOX WIDTH), BH (BOX HEIGHT), A, B, and 20mm/27mm offsets. Label: BACK OF BOTTOM COVER-DROP LINE.

CURTAIN DROP	SINGLE ROLLER BOX - TYPE 1			
	WIDTH(BW)	HEIGHT(BH)	A	B
UPTO 3m	190mm	190mm	163mm	155mm
3m TO 7m	210mm	210mm	183mm	175mm
7m TO 12m	280mm	280mm	253mm	245mm

Diagram of Multiple Roller Box - Type 2 showing dimensions: BW (BOX WIDTH), BH (BOX HEIGHT), A, B, and 20mm/27mm offsets. Label: BACK OF BOTTOM COVER-DROP LINE.

CURTAIN DROP	MULTIPLE ROLLER BOX - TYPE 2			
	WIDTH(BW)	HEIGHT(BH)	A	B
UPTO 3m	190mm	350mm	163mm	155mm
3m TO 7m	210mm	390mm	183mm	175mm
7m TO 12m	280mm	500mm	253mm	245mm

Diagram of Multiple Roller Box - Type 3 showing dimensions: BW (BOX WIDTH), BH (BOX HEIGHT), A, B, and 16mm offset. Label: BACK OF BOTTOM COVER - DROP LINE.

CURTAIN DROP	MULTIPLE ROLLER BOX - TYPE3			
	WIDTH(BW)	HEIGHT(BH)	A	B
UPTO 3m	320mm	190mm	160mm	153mm
3m TO 7m	370mm	210mm	185mm	178mm
7m TO 12m	480mm	280mm	240mm	233mm

Diagram of Single Roller Box - Type 1 showing dimensions: BW (BOX WIDTH), BH (BOX HEIGHT), A, B, and 26mm/27mm offsets. Label: BACK OF BOTTOM COVER-DROP LINE.

CURTAIN

CURTAIN DROP	SINGLE ROLLER BOX - TYPE 1			
	WIDTH(BW)	HEIGHT(BH)	A	B
UPTO 3m	190mm	210mm	163mm	138mm
3m TO 7m	210mm	230mm	183mm	158mm
7m TO 12m	280mm	300mm	253mm	228mm

Diagram of Multiple Roller Box - Type 2 showing dimensions: BW (BOX WIDTH), BH (BOX HEIGHT), A, B, and 26mm offset. Label: BACK OF BOTTOM COVER-DROP LINE.

CURTAIN DROP	MULTIPLE ROLLER BOX - TYPE 2			
	WIDTH(BW)	HEIGHT(BH)	A	B
UPTO 3m	190mm	370mm	163mm	138mm
3m TO 7m	210mm	410mm	183mm	158mm
7m TO 12m	280mm	520mm	253mm	228mm

Diagram of Multiple Roller Box - Type 3 showing dimensions: BW (BOX WIDTH), BH (BOX HEIGHT), A, B, and 26mm offset. Label: BACK OF BOTTOM COVER-DROP LINE.

CURTAIN DROP	MULTIPLE ROLLER BOX - TYPE3			
	WIDTH(BW)	HEIGHT(BH)	A	B
UPTO 3m	320mm	210mm	160mm	136mm
3m TO 7m	370mm	230mm	185mm	161mm
7m TO 12m	480mm	300mm	240mm	216mm

**CUTSHEET**

**SMOKE CURTAIN BOXES**

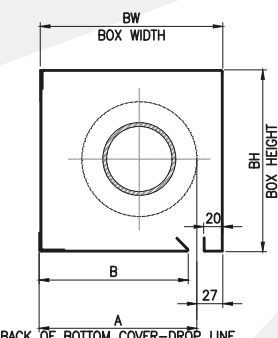

BACK OF BOTTOM COVER-DROP LINE

CURTAIN DROP	SINGLE ROLLER BOX - TYPE 1			
	WIDTH(BW)	HEIGHT(BH)	A	B
UPTO 3m	190mm	190mm	163mm	155mm
3m TO 7m	210mm	210mm	183mm	175mm
7m TO 12m	280mm	280mm	253mm	245mm

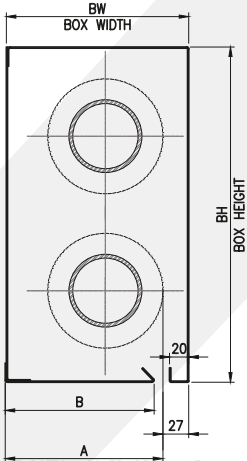

BACK OF BOTTOM COVER-DROP LINE

CURTAIN DROP	MULTIPLE ROLLER BOX - TYPE 2			
	WIDTH(BW)	HEIGHT(BH)	A	B
UPTO 3m	190mm	350mm	163mm	155mm
3m TO 7m	210mm	390mm	183mm	175mm
7m TO 12m	280mm	500mm	253mm	245mm

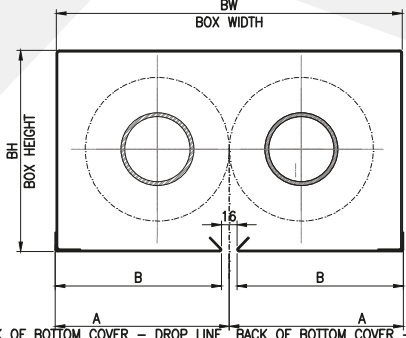

BACK OF BOTTOM COVER - DROP LINE

CURTAIN DROP	MULTIPLE ROLLER BOX - TYPE3			
	WIDTH(BW)	HEIGHT(BH)	A	B
UPTO 3m	320mm	190mm	160mm	153mm
3m TO 7m	370mm	210mm	185mm	178mm
7m TO 12m	480mm	280mm	240mm	233mm

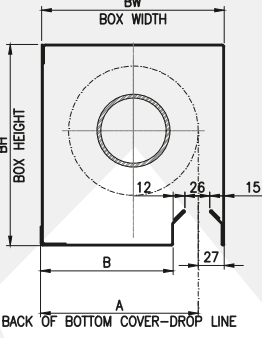

BACK OF BOTTOM COVER-DROP LINE

CURTAIN DROP	SINGLE ROLLER BOX - TYPE 1			
	WIDTH(BW)	HEIGHT(BH)	A	B
UPTO 3m	190mm	210mm	163mm	136mm
3m TO 7m	210mm	230mm	183mm	158mm
7m TO 12m	280mm	300mm	253mm	228mm

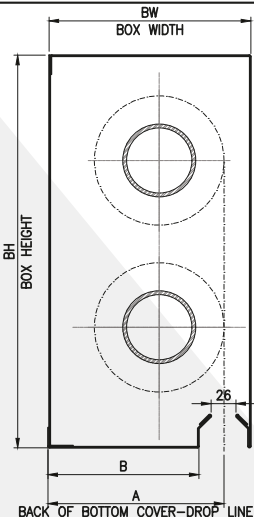

BACK OF BOTTOM COVER-DROP LINE

CURTAIN DROP	MULTIPLE ROLLER BOX - TYPE 2			
	WIDTH(BW)	HEIGHT(BH)	A	B
UPTO 3m	190mm	370mm	163mm	138mm
3m TO 7m	210mm	410mm	183mm	158mm
7m TO 12m	280mm	520mm	253mm	228mm

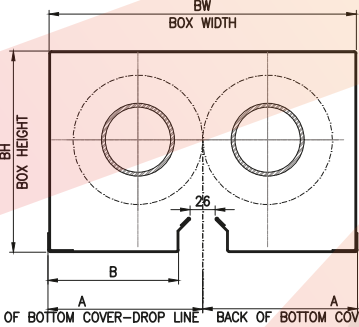

BACK OF BOTTOM COVER-DROP LINE

CURTAIN DROP	MULTIPLE ROLLER BOX - TYPE3			
	WIDTH(BW)	HEIGHT(BH)	A	B
UPTO 3m	320mm	210mm	160mm	136mm
3m TO 7m	370mm	230mm	185mm	161mm
7m TO 12m	480mm	300mm	240mm	216mm

CURTAIN DROP	SMOKE CURTAINS WITHOUT GUIDES			
	WIDTH(BW)	HEIGHT(BH)	A	B
UPTO 1.5m	160mm	180mm	133mm	108mm

CURTAIN DROP	SMOKE CURTAINS WITHOUT GUIDES			
	WIDTH(BW)	HEIGHT(BH)	A	B
UPTO 1.5m	160mm	320mm	133mm	108mm

CURTAIN DROP	SMOKE CURTAINS WITHOUT GUIDES			
	WIDTH(BW)	HEIGHT(BH)	A	B
UPTO 1.5m	280mm	180mm	140mm	116mm

## CUTSHEET



Accordion Curtain - Retracted

### DESCRIPTION

KAYAN Automatic Fire Curtains are life safety systems that are designed to arrest the spread of fire in a building. The assembly comprises a fire resistant fiberglass fabric stacked inside the headbox that is typically installed above the ceiling to be virtually invisible until activated. The curtain descends at a controlled speed upon receipt of signal from a fire alarm and provides resistance for up to 240 minutes.

### PRODUCT ADVANTAGES

- Lightweight & Compact - Reduced headroom requirement compared to a rolling fire shutter.
- State of Art Technology - Manufactured with intricacy using advanced machinery.
- Flexible Design Solution - Meeting Bespoke requirements.
- Improved Aesthetics & Mechanics - Negates the requirement for corner support columns and in some cases, side guides.
- KAYAN Gravity Fail Safe System - Guaranteed deployment of the curtains at a controlled descent rate using our gravity fail safe system. Applies under any scenario such as mains power failure and damage to control systems.

### SYSTEM TESTED IN ACCORDANCE WITH

- UL Listed and classified under the UL follow up third party accreditation service
- UL 10D
- Method of Test NFPA 252
- Compliance with NFPA 80
- Classified to UL 10D for a period of 240 minutes ( 690 Fabric)
- Classified to UL 10D for a period of 60 minutes ( 455 Fabric)
- Tested to ASTM E84 & UL 723 for VG455 Fabric
- BS EN 1634-1:2014+A1:2018 for a period of 120 minutes (520 Fabric)
- Fabric Tested in accordance with BS 476 Pt 6 & Pt 7 and achieved Class 0
- Fabric Impact Tested in accordance with BS 5234-2:1992



Accordion Curtain - Deployed



KAYAN

شركة كيان للسلامة

KAYAN AUTOMATIC ACCORDION CURTAIN

CUTSHEET

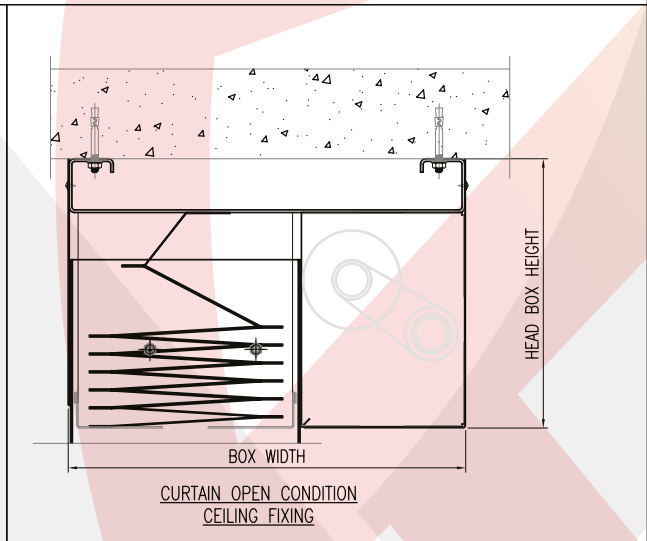
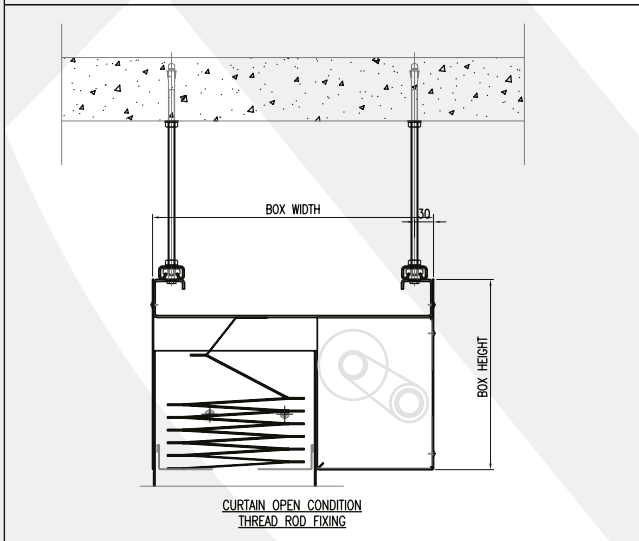
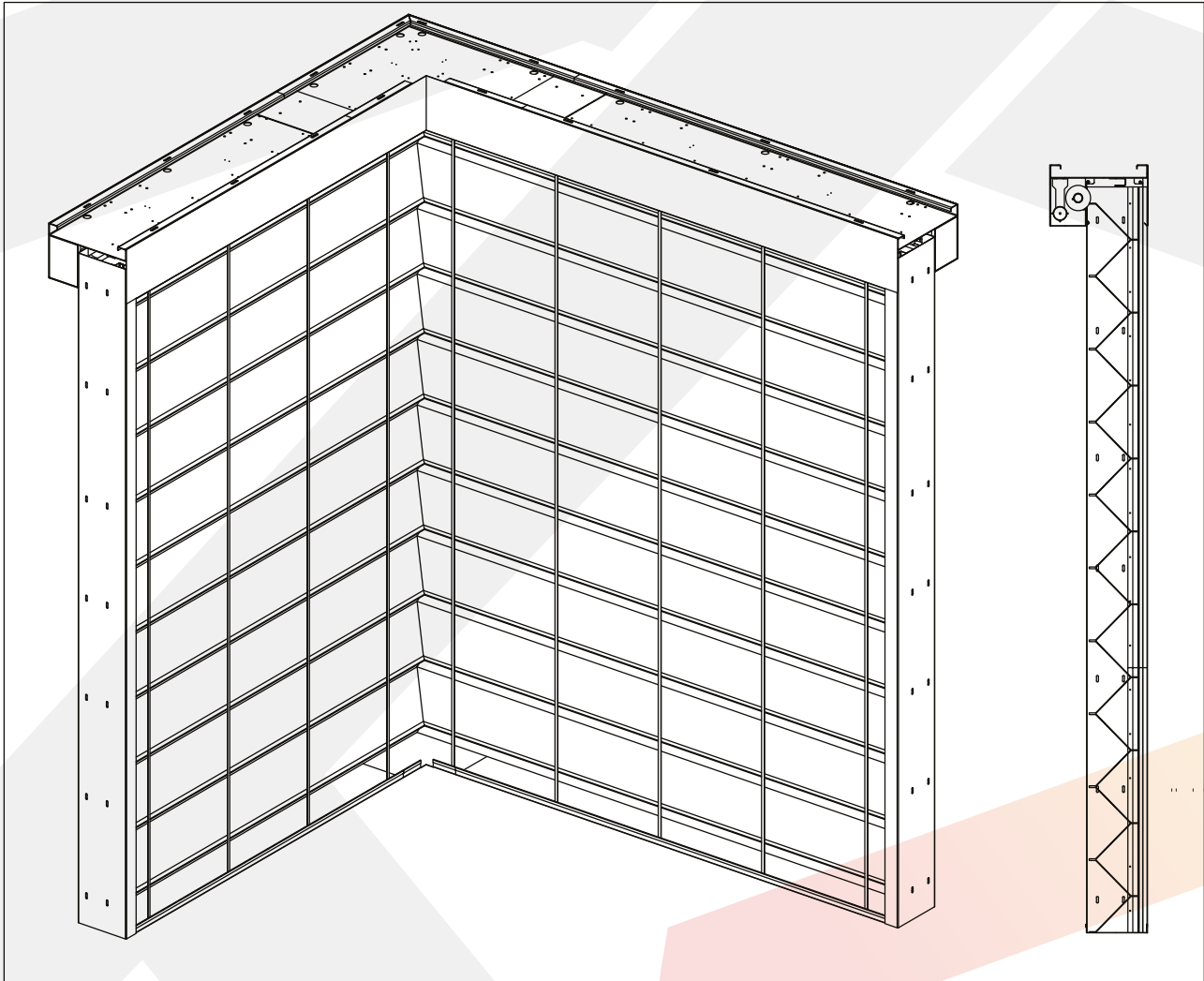

## CUTSHEET



KAYAN Egress Curtain

### DESCRIPTION

KAYAN Automatic Egress Curtains provide cross corridor fire separation without inhibiting the passage of occupants evacuating the building by utilizing an egress door that allows people to pass without retracting the curtain. It is used as a secondary means of escape. KAYAN Egress curtains are used in elevator lobbies, cross corridors, staircase, and emergency exits. The curtain descends at a controlled speed upon receipt of a signal from a fire alarm using kayan's Guaranteed Gravity Fail-Safe System.

### Smoke and Fire Curtain Egress Feature

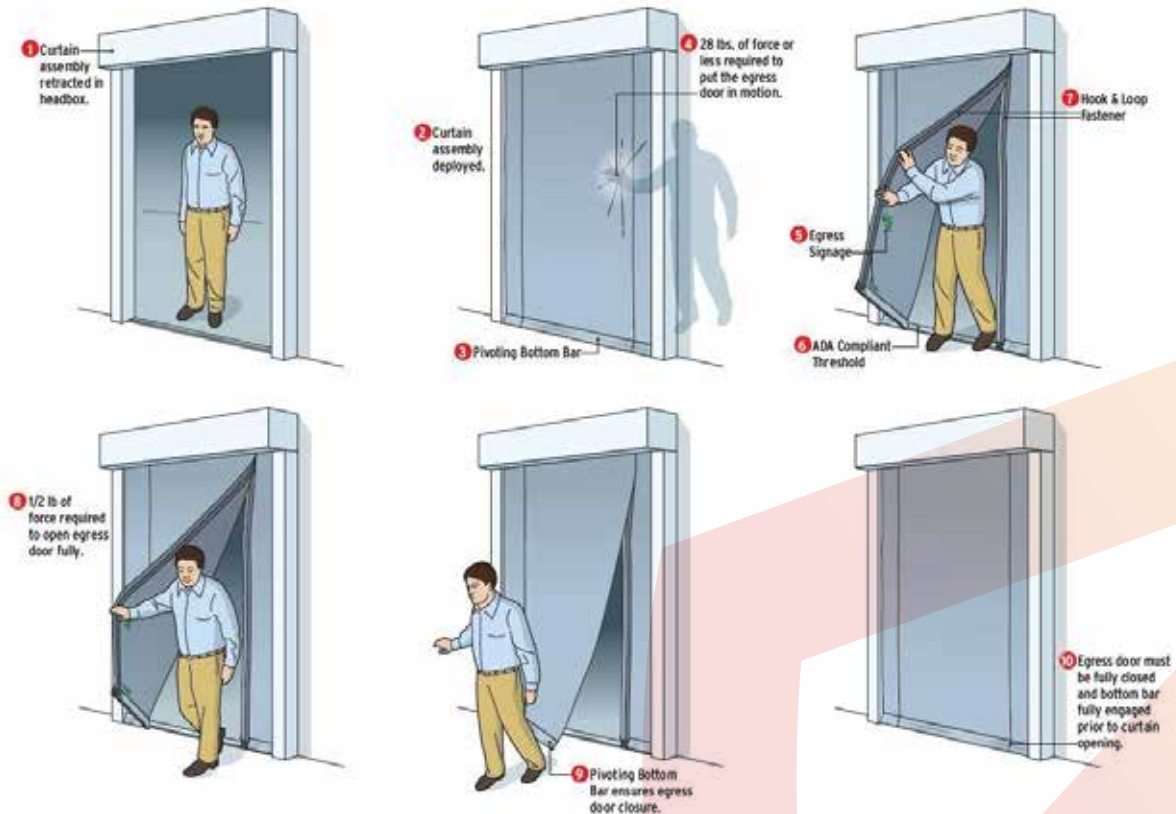

### SYSTEM TESTED IN ACCORDANCE WITH

- Classified to UL 10D for a period of 180 minutes ( 690 Fabric)
- Classified to UL 10D for a period of 60 minutes ( 455 Fabric)
- UL 1784
- ASTM - E84 - VG 455 Fabric - Test Method for surface Burning characteristics of Building Material
- Fabric Impact Tested in accordance with BS 2:1992-5234
- BS 476 Pt 6 (fire propagation) & Pt 7 (surface spread of flame)
- Achieved class 0

### COMPLIANCE

- NFPA 80 Compliance
- NFPA 101 Compliance
- NFPA 105 Compliance

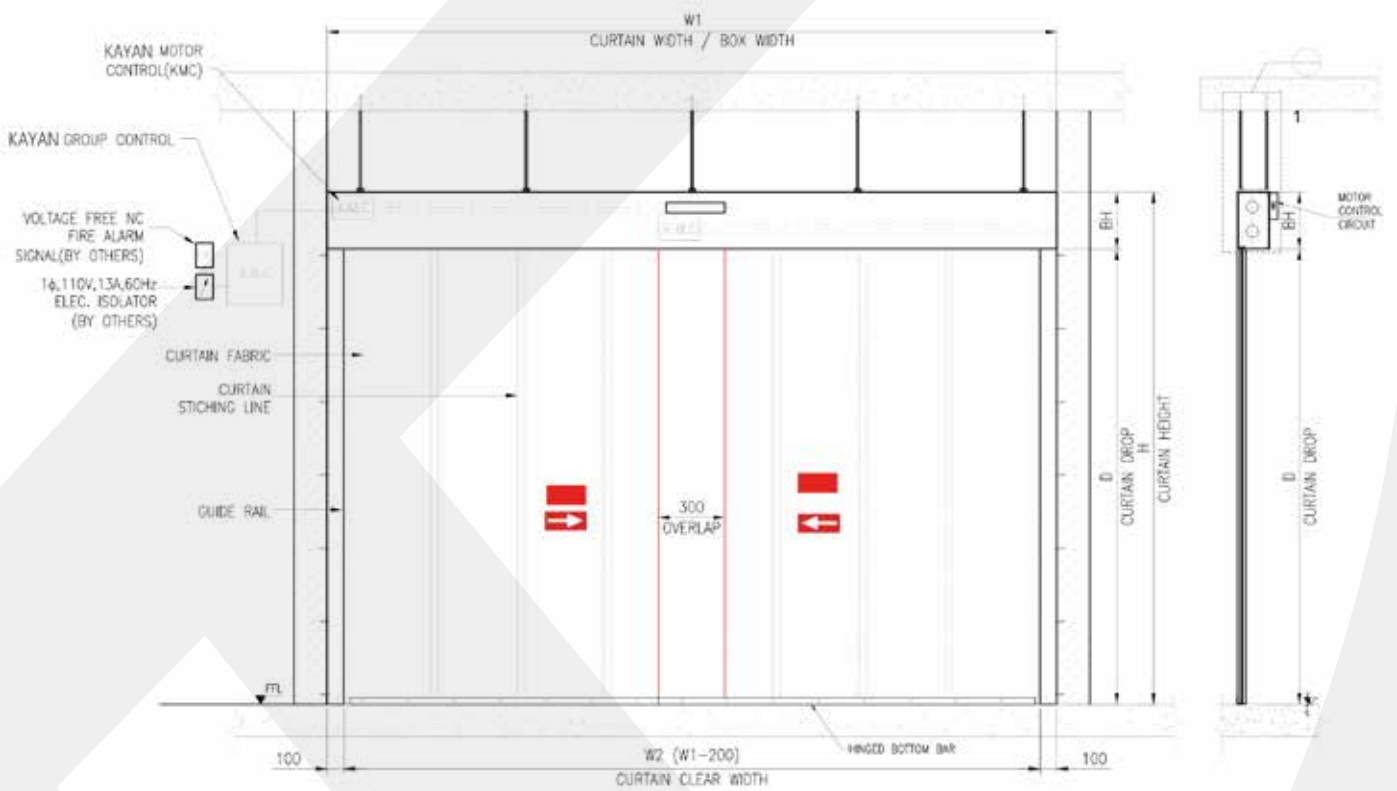

## CUTSHEET



### DESCRIPTION

The KAYAN Horizontal Curtain is a fire rated assembly designed to function as a horizontally deploying opening protective.

The system is activated upon receipt of a signal from the:

- General Fire Alarm
- Smoke Detection System
- BMS Module

The system is driven by a 24V DC motor arrangement or 230V AC motor subject to size. If a 230V motor is selected it should be connected to an independent UPS system in case of power failure.

### PRODUCT ADVANTAGES

- Lightweight & Compact: Reduced headroom requirement.
- Flexible Design Solution: Meeting Bespoke requirements.
- Improved Aesthetics
- Mounting Options: Above the slab or Under the slab.

### SYSTEM TESTED IN ACCORDANCE WITH

- System tested in accordance with BS EN 1634 Part 1 for up to 240 minutes.
- System tested in accordance with UL 10D for 180 minutes
- Compliance with NFPA 80
- Method of Test NFPA 252
- Fabric: VWG690
- Stitch Load Test: Fabric tested to 500Pa of Pressure.
- Fabric Impact Test: Fabric tested in accordance with BS 5234-2 to double severe duty

### SYSTEM COMPONENTS

- Headbox: The steel headbox houses the roller, fabric and motor within the casing creating a small compact package that remains virtually invisible
- Fabric: Woven Fiberglass wire reinforced fabric with individual panels stitched and hemmed using stainless steel thread
- Bottom Bar: The bottom bar is 3mm GI sheet material which provides opening and holding of the fabric in a conditioned way.
- Side guide: During Deployment, slim steel side guides fabricated from 2 mm GI rolled Profile prevent derailment of the fabric during operation ensuring integrity of the system when faced by positive or negative pressures of fire.



## HEADBOX

MULTIPLE ROLLER ASSEMBLIES SHOWING OVER-UNDER AND SIDE BY SIDE ARRANGEMENT WITH BOTTOM BAR FLUSH WITH UNDERSIDE OF HEADBOX

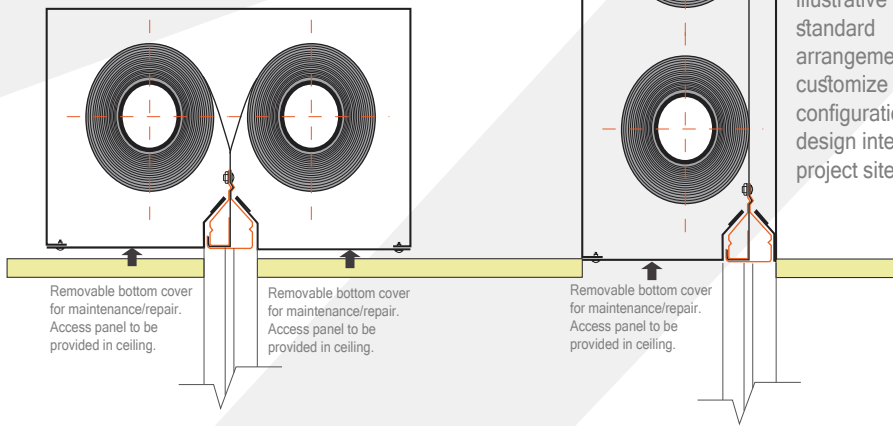

These are for illustrative purposes of standard arrangements. We can customize the configuration to suit design intent and project site conditions.

### SINGLE ROLLER

ASSEMBLY WITH ALTERNATE BOTTOM BAR DROPPED TO CEILING

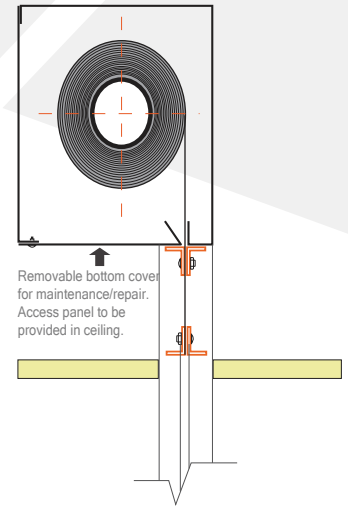

## Headbox Fixing

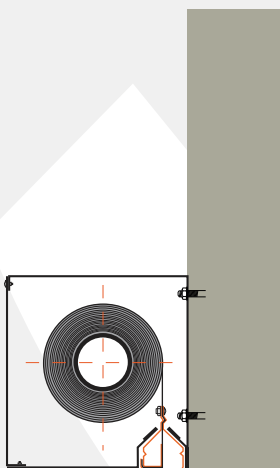

**FACE FIXED**  
Fixed directly to the lintel above an opening.

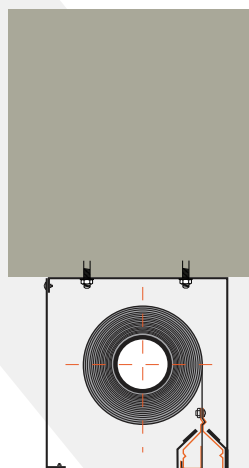

**SOFFIT FIXED**  
Fixed directly to the underside of the soffit slab.

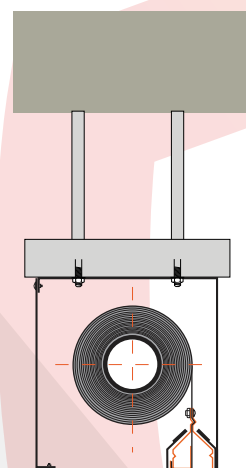

**SOFFIT SUSPENDED**  
Suspended from soffit via uni-struts and drop rods

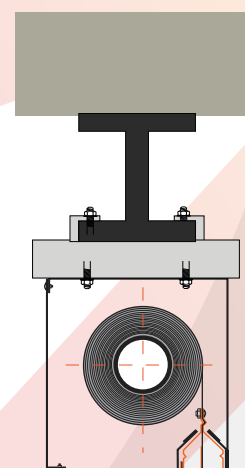

**I-BEAM**  
Clamped to a steel beam

## SINGLE ROLLER ASSEMBLY



### 1. HEADBOX

The steel headbox houses the roller, fabric and motor within the casing creating a small compact package that remains virtually invisible above the ceiling.

### 2. ROLLER AND TUBULAR MOTOR

A tubular motor drives a steel roller tube to retract and deploy the fabric from normal position in the headbox to its operational position.

### 3. GUIDE RAIL

During deployment, slim steel side guides prevent derailment of the fabric during operation ensuring integrity of the system when faced by positive or negative pressures of a real fire.

### 4. FABRIC CURTAIN

Woven fiberglass wire reinforced fabric with individual panels stitched and hemmed using stainless steel thread.

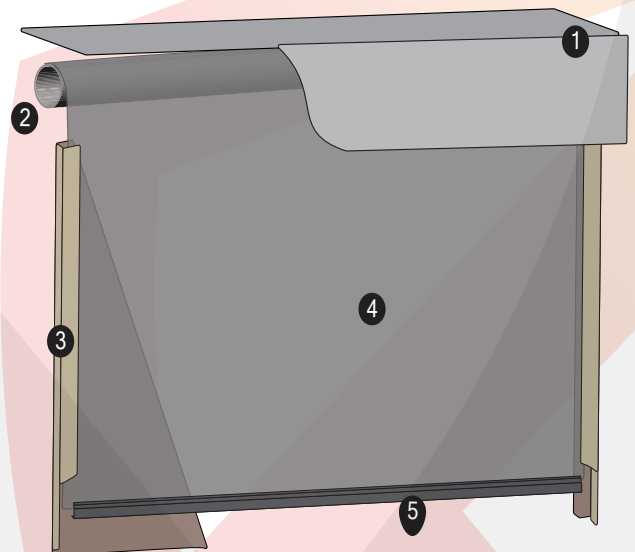

### SINGLE ROLLER ASSEMBLY

Smaller widths can be spanned by a single roller assembly.

## MULTIPLE ROLLER ASSEMBLY



### 5. STEEL BOTTOM BAR

The KAYAN profile bottom bar provides weight and stability to the system ensuring a gravity fail safe deployment.

### 6. OVER-UNDER ROLLER ARRANGEMENT

An over-under or side by side arrangement of the barrels (to suit the project requirements) allows multiple rollers to be enclosed in a single compact headbox.

### 7. FABRIC OVERLAP

Multiple rollers utilize the use of a 500mm overlap arrangement which removes the need for intermediate side guides and minimizes the potential for roller bounce.

### 8. CONJOINED BOTTOM BAR

A conjoined bottom bar runs the entire width of the curtain.

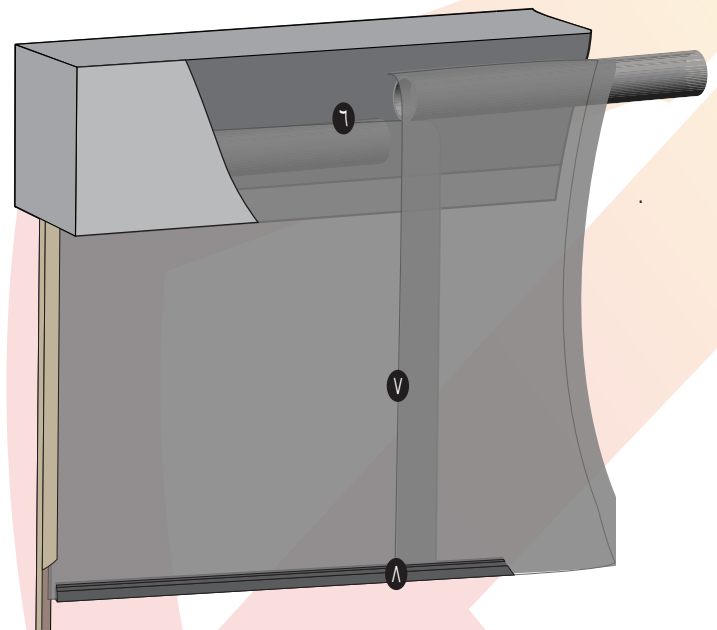

## BOTTOM BAR

Our bottom bar profile is designed to provide the necessary weight to draw the curtain down during a gravity safe deployment and to stabilize the curtain during descent. Rolled from galvanized steel, we can powdercoat the bottom bar to match

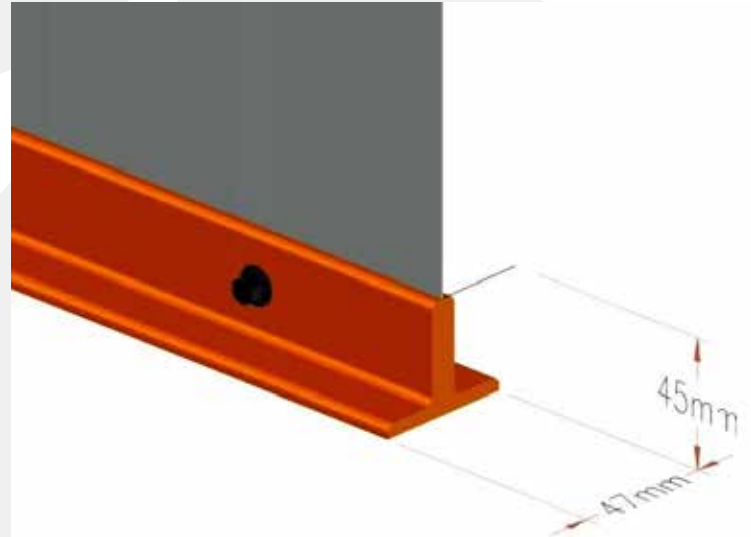

## SIDE GUIDES

Our fire curtain steel side guides can be powdercoated to blend in with the surround wall. In a real fire, these guides help the curtains withstand positive and negative pressures. The stitched fabric inserted into the guide rail is provided with retainer tabs for added strength.

Designed to be slim and as unobtrusive as possible, the side guides can be fixed to the building structure in 3 ways illustrated above. Our side guides are provided with capped holes that allow for bolting the guides to the wall without the need for visible fixing angles, further reducing the guide footprint.

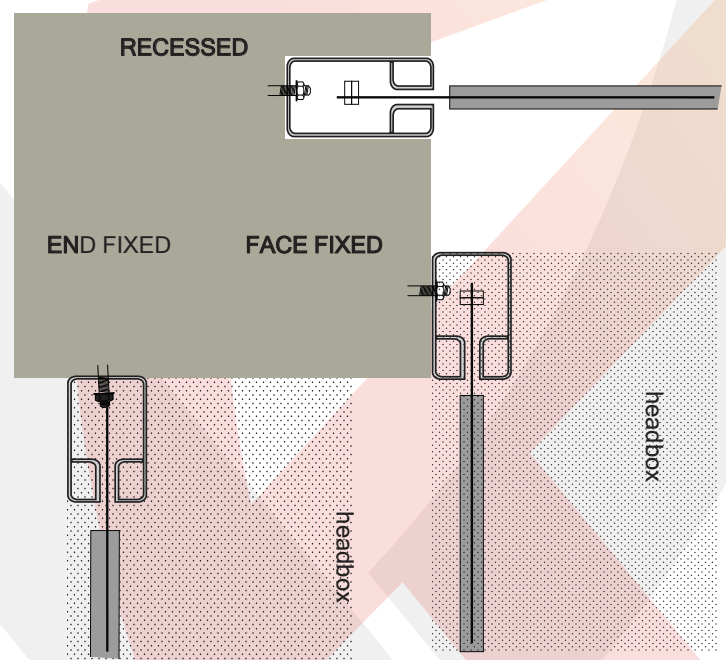
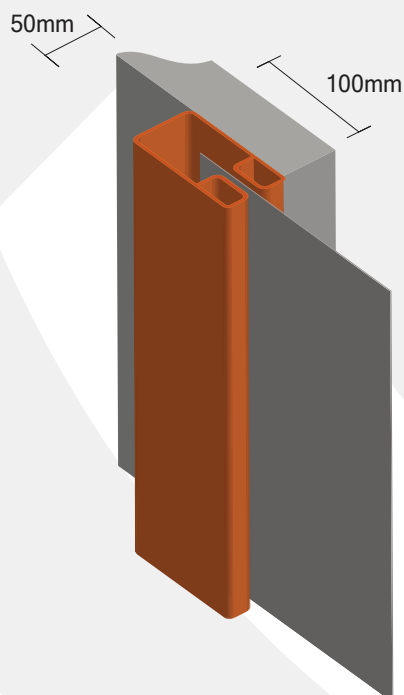

## TEST REPORT

Issue Date: 2022-05-09



Fig. 5 Unexposed Side to Temperature/Time Resistance Test after 10 Minutes



Fig. 6 Unexposed Side to Temperature/Time Resistance Test after 60 Minutes

## TEST REPORT

Issue Date: 2022-05-09



Fig. 7 Unexposed Side to Temperature/Time Resistance Test after 90 Minutes



Fig. 8 Unexposed Side to Temperature/Time Resistance Test after 120 Minutes



# PROJECTS

**Valy Almadina Hotel, Central  
Area, Land No 4060, Medina KSA**



# PROJECTS

ELMEHRAB TAIBA HOTEL,CENTRAL  
AREA, LAND NO 3139 MEDINA KSA



# PROJECTS

**BIN DAWOOD MARKET,  
MEDINA KSA**



فندق كاسبر

# PROJECTS

CASTLE HOTEL (Mobco), CENTRAL  
AREA, LAND NO 3127, MEDINA KSA

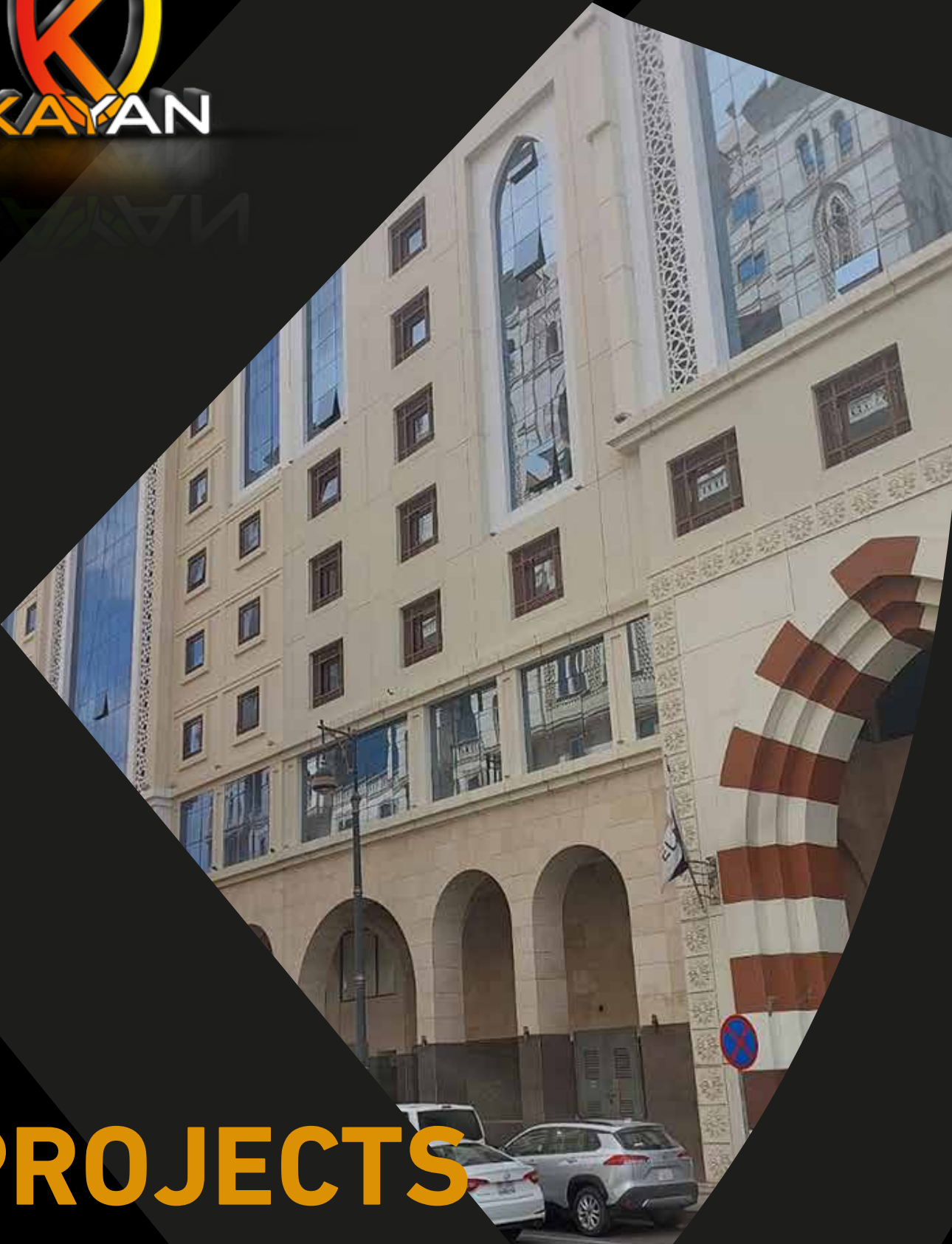

# PROJECTS

**Mesan Almisk Hotel, Central  
Area, Land No 3126, Medina KSA**



# PROJECTS

ALNZRA ELMOSTABLIA COMPANY  
HOTEL,CENTRAL AREA,LAND NO  
192,MEDINA KSA

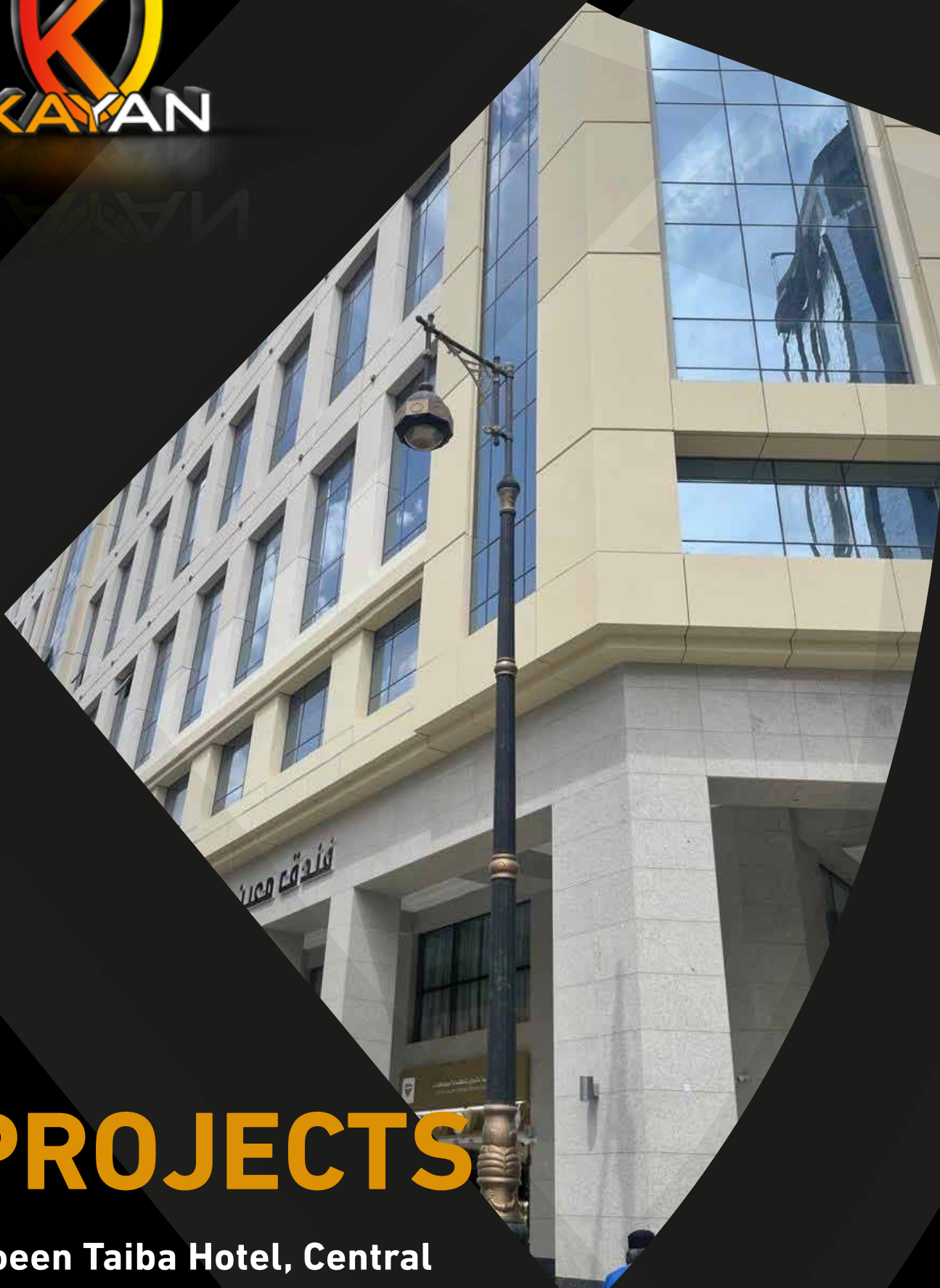

# PROJECTS

**Moeen Taiba Hotel, Central  
Area, Land No 4060, Medina KSA**



# PROJECTS

Rose Hotel, Central Area, Land  
no 4061/4062, Medina KSA



# PROJECTS

**Four Season Hotel, Central  
Area, Land No 4059, Medin KSA**





# PROJECTS

Commercial Building,  
Riyadh City



# PROJECTS

AlHodib Center, Jeddah City

## CERTIFICATIONS AND APPROVALS

